

INFORMACIÓN GENERAL

Detección	Previsto para detectores magnéticos de posición
Fluido	Aire o gas neutro filtrado, lubricado o no
Presión de utilización	10 bar máximo
Temperatura admisible	-10°C a +70°C
Normas	CNOMO 06-07-02 a 06-07-15 AFNOR NF E 49001 - NF E 49002 NF E 49011a NF E 49015

CONSTRUCCIÓN

Tubo amagnético	Aleación de aluminio anodizado duro
Tirantes	Acero inox (Ø 32 a 100 mm), acero pintado (Ø 25,125 a 200 mm)
Vástago	Acero cromado duro
Pistón	POM (poliacetal) y acero cincado o aleación ligera equipado de un imán permanente anular
Juntas de pistón	PUR (poliuretano) o NBR (nitrilo)
Junta de amortiguación	NBR (nitrilo)
Fondos delantero y trasero	Zamak (Ø 25 mm) - aleación (Ø 32 a 200 mm)
Casquillo metálico	Autolubricante
Tuerca de vástago	Acero cincado
Amortiguación	Neumática, regulable por los 2 lados

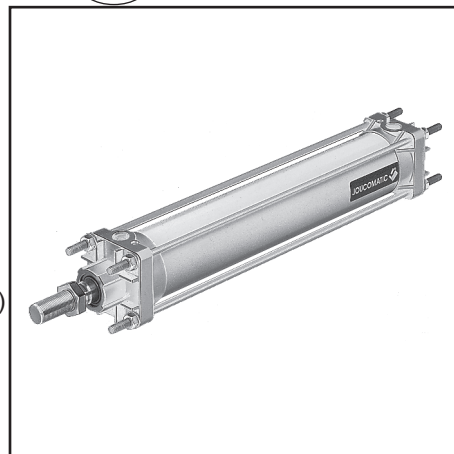

Longitud de amortiguación :
 Ø 25 y 32 mm = 15 mm
 Ø 40 y 50 mm = 20 mm
 Ø 63 y 80 mm = 21 mm
 Ø 100 y 125 mm = 24 mm
 Ø 160 y 200 mm = 30 mm

SELECCIÓN DEL MATERIAL

Ø (mm)	carrera (mm)	código *	referencia	Ø racordaje
25	50	43700999	PCN 25 A 50 - DM	G 1/8
	100	43701000	PCN 25 A 100-DM	
	150	43701001	PCN 25 A 150-DM	
	200	43701002	PCN 25 A 200-DM	
	250	43701003	PCN 25 A 250-DM	
32	50	43701004	PCN 32 A 50 - DM	G 1/8
	100	43701005	PCN 32 A 100-DM	
	150	43701006	PCN 32 A 150-DM	
	200	43701007	PCN 32 A 200-DM	
	250	43701008	PCN 32 A 250-DM	
40	50	43701009	PCN 40 A 50 - DM	G 1/4
	100	43701010	PCN 40 A 100-DM	
	150	43701011	PCN 40 A 150-DM	
	200	43701012	PCN 40 A 200-DM	
	250	43701013	PCN 40 A 250-DM	
50	50	43701014	PCN 40 A 300-DM	G 1/4
	100	43701015	PCN 40 A 400-DM	
	150	43701016	PCN 50 A 50 - DM	
	200	43701017	PCN 50 A 100-DM	
	250	43701018	PCN 50 A 150-DM	
63	300	43701019	PCN 50 A 200-DM	G 1/4
	400	43701020	PCN 50 A 250-DM	
	500	43701021	PCN 50 A 300-DM	
	600	43701022	PCN 50 A 400-DM	
	50	43701023	PCN 63 A 50 - DM	
100	43701024	PCN 63 A 100-DM		
150	43701025	PCN 63 A 150-DM		
200	43701026	PCN 63 A 200-DM		
250	43701027	PCN 63 A 250-DM		
80	300	43701028	PCN 63 A 300-DM	G 3/8
	400	43701029	PCN 63 A 400-DM	
	500	43701030	PCN 63 A 500-DM	
	600	43701031	PCN 63 A 600 S	
	50	43701032	PCN 80 A 50 - DM	
	100	43701033	PCN 80 A 100-DM	
	150	43701034	PCN 80 A 150-DM	
	200	43701035	PCN 80 A 200-DM	
	250	43701036	PCN 80 A 250-DM	
	300	43701037	PCN 80 A 300-DM	
400	43701038	PCN 80 A 400-DM		
500	43701039	PCN 80 A 500-DM		
600	43701040	PCN 80 A 600-DM		

Ø (mm)	carrera (mm)	código *	referencia	Ø racordaje
100	50	43701329	PCN 100 A 50 - DM	G 1/2
	100	43701330	PCN 100 A 100 - DM	
	150	43701331	PCN 100 A 150 - DM	
	200	43701332	PCN 100 A 200 - DM	
	250	43701333	PCN 100 A 250 - DM	
	300	43701334	PCN 100 A 300 - DM	
	400	43701335	PCN 100 A 400 - DM	
	500	43701336	PCN 100 A 500 - DM	
	600	43701337	PCN 100 A 600 - DM	
	700	43701338	PCN 100 A 700 - DM	
	800	43701339	PCN 100 A 800 - DM	
900	43701340	PCN 100 A 900 - DM		
1000	43701341	PCN 100 A 1000-DM		
125	50	43701355	PCN 125 A 50 - DM	G 1/2
	100	43701356	PCN 125 A 100 - DM	
	150	43701357	PCN 125 A 150 - DM	
	200	43701358	PCN 125 A 200 - DM	
	250	43701359	PCN 125 A 250 - DM	
	300	43701360	PCN 125 A 300 - DM	
	400	43701361	PCN 125 A 400 - DM	
	500	43701362	PCN 125 A 500 - DM	
	600	43701363	PCN 125 A 600 - DM	
	700	43701364	PCN 125 A 700 - DM	
	800	43701365	PCN 125 A 800 - DM	
900	43701366	PCN 125 A 900 - DM		
1000	43701367	PCN 125 A 1000-DM		
160	50	43701381	PCN 160 A 50 - DM	G 3/4
	100	43701382	PCN 160 A 100 - DM	
	150	43701383	PCN 160 A 150 - DM	
	200	43701384	PCN 160 A 200 - DM	
	250	43701385	PCN 160 A 250 - DM	
	300	43701386	PCN 160 A 300 - DM	
	400	43701387	PCN 160 A 400 - DM	
	500	43701388	PCN 160 A 500 - DM	
	600	43701389	PCN 160 A 600 - DM	
	700	43701390	PCN 160 A 700 - DM	
	800	43701391	PCN 160 A 800 - DM	
900	43701392	PCN 160 A 900 - DM		
1000	43701393	PCN 160 A 1000-DM		
200	50	43701407	PCN 200 A 50 - DM	G 3/4
	100	43701408	PCN 200 A 100 - DM	
	150	43701409	PCN 200 A 150 - DM	
	200	43701410	PCN 200 A 200 - DM	
	250	43701411	PCN 200 A 250 - DM	
	300	43701412	PCN 200 A 300 - DM	
	400	43701413	PCN 200 A 400 - DM	
	500	43701414	PCN 200 A 500 - DM	
	600	43701415	PCN 200 A 600 - DM	
	700	43701416	PCN 200 A 700 - DM	
	800	43701417	PCN 200 A 800 - DM	
900	43701418	PCN 200 A 900 - DM		
1000	43701419	PCN 200 A 1000-DM		

* Los detectores magnéticos de posición se solicitan por separado :
 - modelo "T" (ver página P291)
 - modelo BIM, magnético inductivo (ver página P297)

00343ES-2011/R01
 Las especificaciones y dimensiones pueden ser modificadas sin previo aviso. Todos los derechos reservados.

FIJACIONES

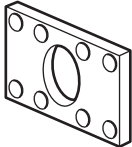
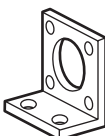
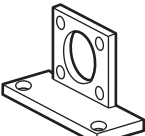
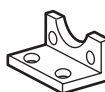
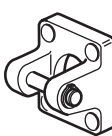
∅					
	Placa delantera o trasera CNOMO 06-07-04	Escuadra alta Normal CNOMO 06-07-05	Escuadra alta Ancha CNOMO 06-07-06	Escuadra baja * acero embutido	Articulación hembra delantera o trasera CNOMO 06-07-09
25	43900101	43900061	43900071	43900169	43900031
32	43900102	43900062	43900072	43900170	43900032
40	43900103	43900063	43900073	43900171	43900033
50	43900104	43900064	43900074	43900172	43900034
63	43900105	43900065	43900075	43900173	43900035
80	43900106	43900066	43900076	43900174	43900036
100	43900107	43900067	43900077	43900175	43900037
125	43900108	43900068	43900078	43900176	43900038
160	43900109	43900069	43900079	43900177	43900039
200	43900110	43900070	43900080	43900178	43900040

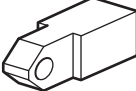
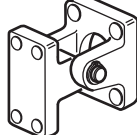
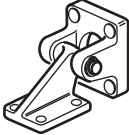
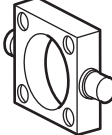
∅					
	Horquilla hembra vástago CNOMO 06-07-14	Horquilla macho vástago CNOMO 06-07-15	Articulación completa normal CNOMO 06-07-10	Articulación completa de escuadra CNOMO 06-07-11	Charnela ** macho CNOMO 06-07-12
25	43900091	43900081	43900021	43900011	410500
32	43900091	43900081	43900022	43900012	410501
40	43900093	43900083	43900023	43900013	410502
50	43900093	43900083	43900024	43900014	410503
63	43900095	43900085	43900025	43900015	410504
80	43900095	43900085	43900026	43900016	410505
100	43900097	43900087	43900027	43900017	410506
125	43900097	43900087	43900028	43900018	410507
160	43900099	43900089	43900029	43900019	410508
200	43900099	43900089	43900030	43900020	410509

* Corresponde a un lote de 2 piezas

** El código de la charnela macho así como la cota G (ver página P245-8) y el eventual código de orientación de los orificios hay que añadirlos al código del cilindro.

NOTA : Las fijaciones son comunes a los cilindros TRINORM-CNOMO con y sin detectores de posición.

A excepción de la charnela macho, las fijaciones se suministran sin montar.

DIMENSIONES (mm)  : ver páginas siguientes

OPCIONES Y VERSIONES ESPECIALES

- Otras carreras bajo demanda
- Versión no amortiguada (NA) y/o no prevista para detectores magnéticos bajo demanda.
- Orientación standard de la charnela : eje de la charnela perpendicular a los orificios de alimentación - código **410002** (la otra posición bajo demanda - código **410003**)
- Vástago de acero inox 316L, código : **995002** - de acero inox 303, código : **995202**
- Prolongación de vástago de acero cromado, código : **995003** - de acero inox 316L, código : **995004** - de acero inox 303, código : **995204**
- Vástago pasante, consultar

Otras opciones y versiones especiales: consultar

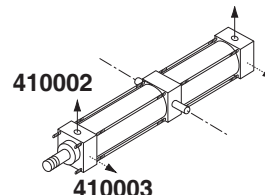

DIMENSIONES (mm), PESOS (kg)

Cilindro solo - CNOMO 06.07.02

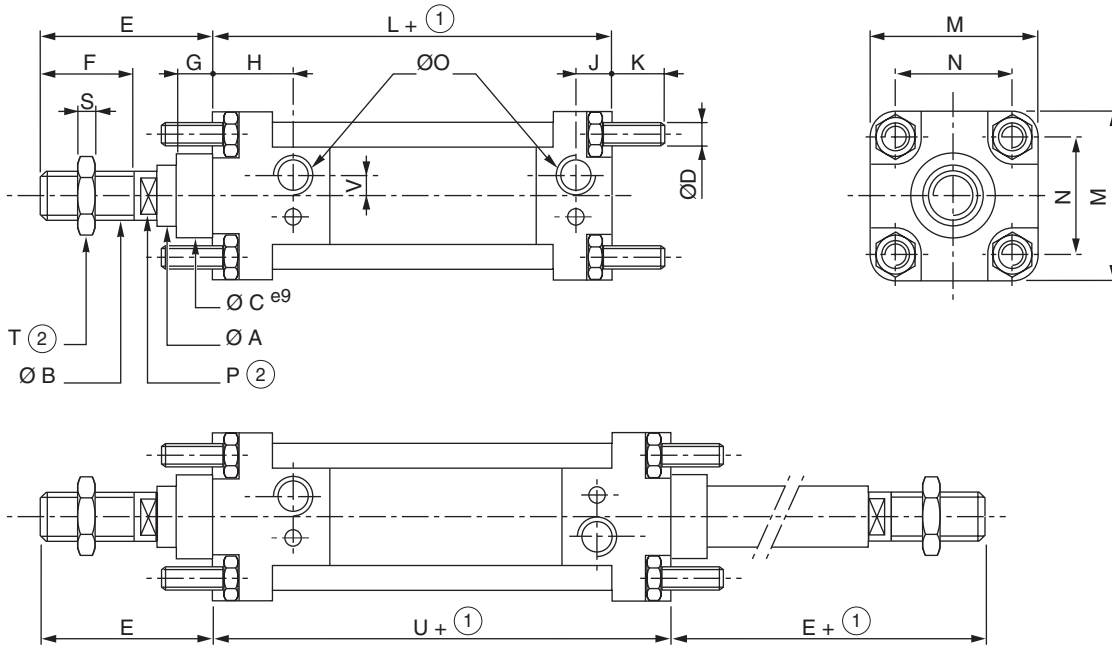

- ① Carrera
- ② Cotas entre caras

Ø	A	B	C	D	E	F	G	H	J	K	L	M	N	O	P	S
25	12	M10 x 1,5	25	M6	45	20	15	14	14	17	80	40	28	G1/8	8	5
32	12	M10 x 1,5	25	M6	45	20	15	1	11,5	17	80	45	33	G1/8	8	5
40	18	M16 x 1,5	32	M6	70	36	15	29,5	11	17	110	52	40	G1/4	13	8
50	18	M16 x 1,5	32	M8	70	36	15	29,5	14	23	110	65	49	G1/4	13	8
63	22	M20 x 1,5	45	M8	85	46	20	33	16	23	125	75	59	G3/8	17	10
80	22	M20 x 1,5	45	M10	85	46	20	33	16	28	125	95	75	G3/8	17	10
100	30	M27 x 2	55	M10	110	63	20	30	30	28	145	115	90	G1/2	22	13,5
125	30	M27 x 2	55	M12	110	63	20	36,5	18	34	145	140	110	G1/2	22	13,5
160	40	M36 x 2	65	M16	135	85	25	39	20	42	180	180	140	G3/4	32	18
200	40	M36 x 2	65	M16	135	85	25	39	20	42	180	220	175	G3/4	32	18

Ø	T	U	V	peso	
				(3)	(4)
25	17	90	2,5	0,520	0,280
32	17	90	4	0,640	0,320
40	24	129	1,5	0,910	0,470
50	24	129	4	1,200	0,600
63	30	146	5,5	1,970	0,830
80	30	146	5,5	2,700	1,100
100	41	164	-	5,100	1,280
125	41	164	-	6,500	2,000
160	54	200	-	13,550	3,250
200	54	200	-	18,000	4,100

(3) Peso de los cilindros con una carrera de 0 mm
(4) Peso a añadir por cada 100 mm de carrera suplementaria.

DIMENSIONES (mm), PESOS (kg)

Fijación por placa delantera o trasera - CNOMO 06-07-04

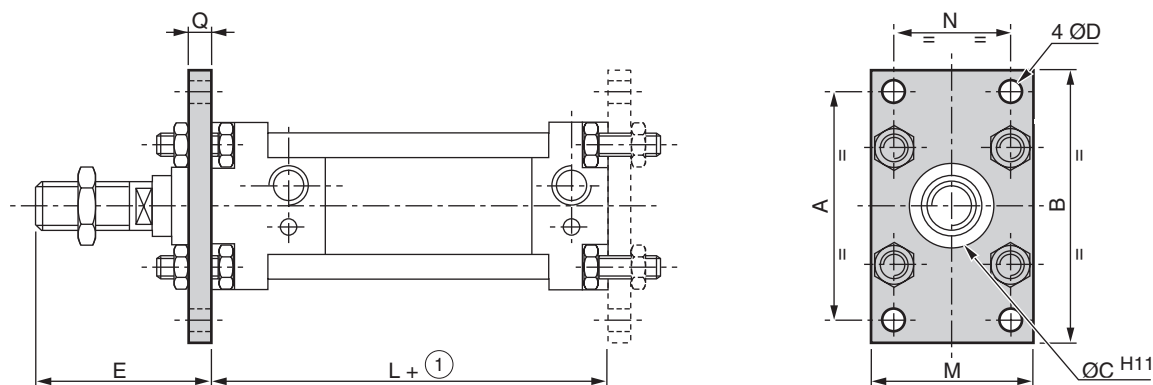

Fijación por escuadra alta normal - CNOMO 06-07-05

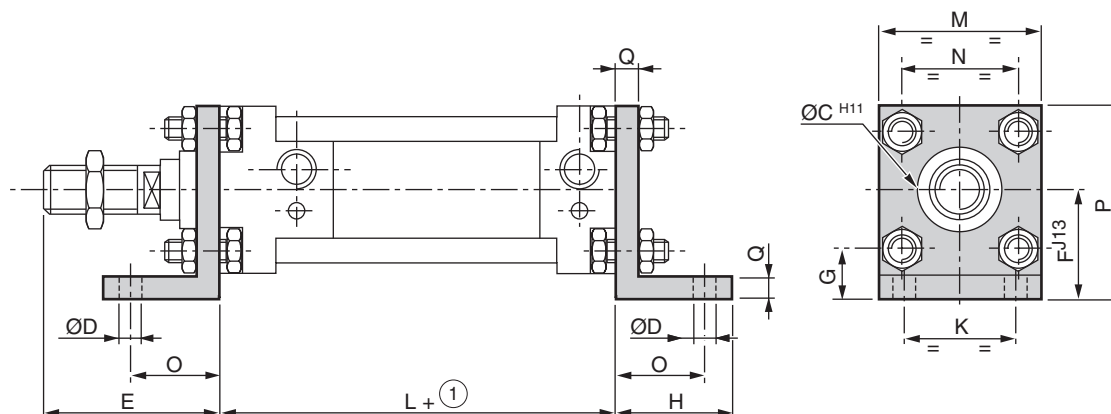

① Carrera

Ø	A	B	ØC	ØD	E	F	G	H	K	L	M	N	O	P	Q
25	68	80	25	9	45	30	16	35	24	80	40	28	27	50	8
32	68	80	25	9	45	32	15,5	35	28	80	45	33	27	54	8
40	78	90	32	9	70	36	16	35	36	110	52	40	27	62	8
50	94	110	32	11	70	45	20,5	45	45	110	65	49	35	77	10
63	104	120	45	11	85	50	20,5	45	55	125	75	59	35	87	10
80	130	150	45	14	85	63	25,5	55	70	125	95	75	43	110	12
100	150	170	55	14	110	73	28	55	90	145	115	90	43	130	12
125	180	205	55	18	110	91	36	68	100	145	140	110	52	161	16
160	228	260	65	22	135	115	45	80	130	180	180	140	62	205	20
200	268	300	65	22	135	135	47,5	80	170	180	220	175	62	245	20

Ø	peso	
	placa delantera o trasera	escuadra alta
25	0,140	0,140
32	0,170	0,180
40	0,220	0,220
50	0,440	0,470
63	0,530	0,550

Ø	peso	
	placa delantera o trasera	escuadra alta
80	1,080	1,090
100	1,520	1,500
125	3,060	3,240
160	6,380	6,350
200	9,580	9,150

Consulte nuestra documentación en : www.asconumatics.eu

DIMENSIONES (mm), PESOS (kg)

Fijación por escuadra alta ancha - CNOMO 06-07-06

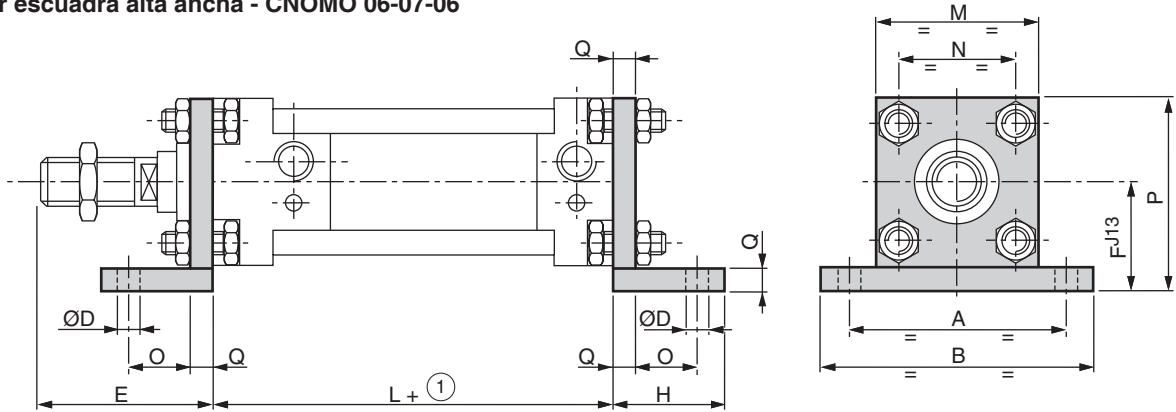

Fijación por escuadra baja de acero embutido

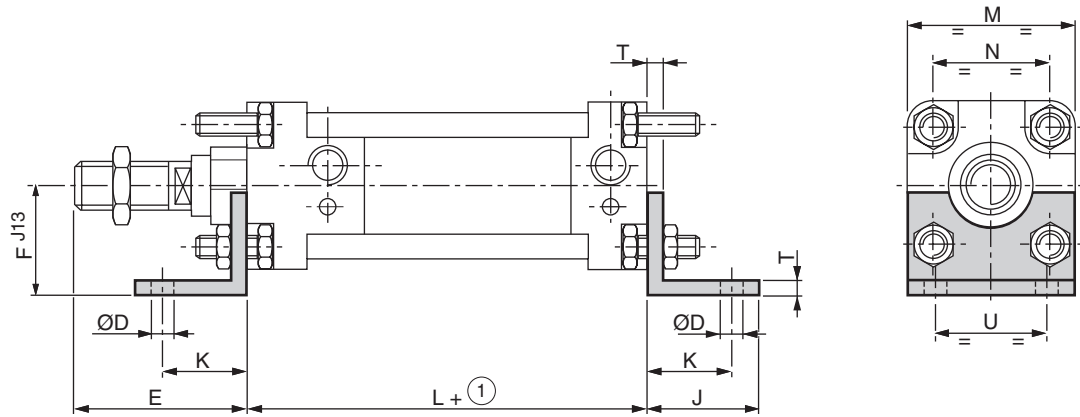

① Carrera

Ø	A	B	ØD	E	F	H	J	K	L	M	N	O	P	Q	T	U
25	58	75	9	45	30	35	35	27	80	40	28	10	50	8	2,5	24
32	65	82	9	45	32	35	37,5	27	80	45	33	10	54	8	3	28
40	72	90	9	70	36	35	35	27	110	52	40	10	62	8	3	36
50	90	110	11	70	45	45	45	35	110	65	49	12	77	10	4	45
63	100	120	11	85	50	45	45	35	125	75	59	12	87	10	4	55
80	126	155	14	85	63	55	55,5	43	125	95	75	16	110	12	5	70
100	148	180	14	110	73	55	55	43	145	115	90	16	130	12	5	90
125	180	215	18	110	91	68	72	52	145	140	110	16	161	16	5	100
160	230	275	22	135	115	80	87	62	180	180	140	20	205	20	6	130
200	270	315	22	135	135	80	95	62	180	220	175	20	245	20	6	170

Ø	peso	
	escuadra alta	escuadra baja
25	0,220	0,100
32	0,260	0,120
40	0,310	0,150
50	0,620	0,310
63	0,720	0,340

Ø	peso	
	escuadra alta	escuadra baja
80	1,390	0,700
100	1,820	0,740
125	3,910	1,350
160	7,770	2,570
200	10,790	3,450

00343ES-2005/R01 Las especificaciones y dimensiones pueden ser modificadas sin previo aviso. Todos los derechos reservados.

DIMENSIONES (mm), PESOS (kg)

Fijación por articulación hembra delantera o trasera - CNOMO 06-07-09

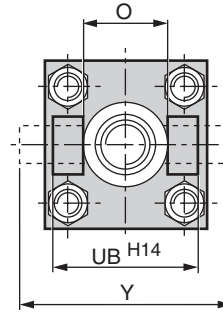
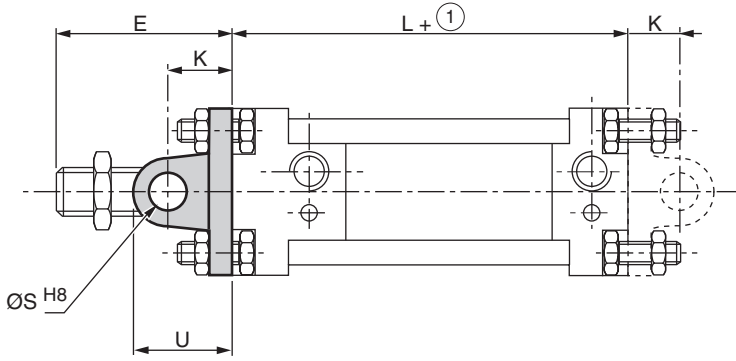

Horquilla hembra - CNOMO 06-07-14

Ø 25...80 mm

Ø 100...200 mm

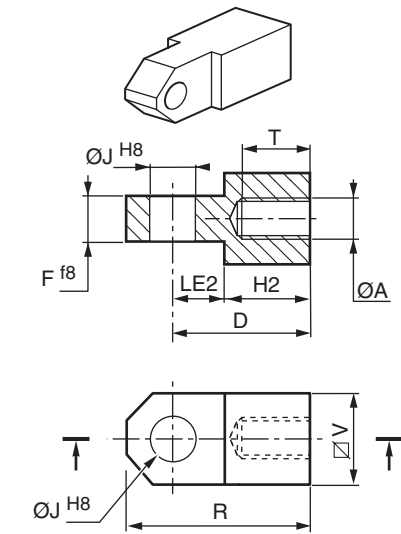
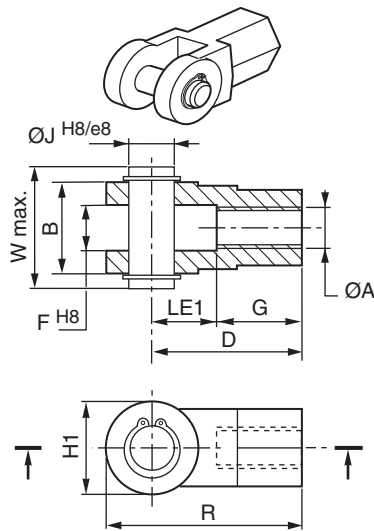
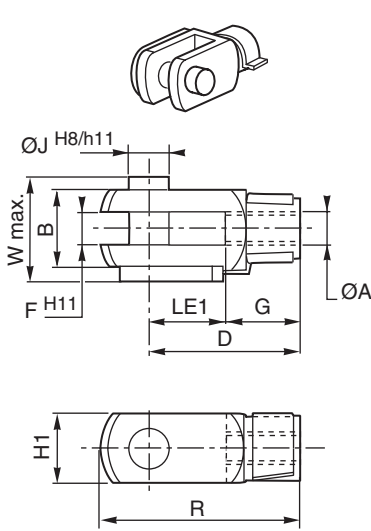

① Carrera

Ø	A	B	D	E	F	G	H1	H2	J	K	L	LE1	LE2	O	R	ØS	T	U	UB	V	W	Y
25	M10 x 1,5	22	36	45	11	20	22	25	8	18	80	16	11	26	45	8	20	26	40	22	28	49
32	M10 x 1,5	22	36	45	11	20	22	25	8	18	80	16	11	26	45	8	20	26	45	22	28	54
40	M16 x 1,5	36	51	70	18	26	26	34	12	24	110	25	17	33	64	12	30	36	52	32	44	62
50	M16 x 1,5	36	51	70	18	26	26	34	12	26	110	25	17	33	64	12	30	38	60	32	44	70
63	M20 x 1,5	45	63	85	22	30	34	41	16	30	125	33	22	47	80	16	36	46	70	35	53	80
80	M20 x 1,5	45	63	85	22	30	34	41	16	32	125	33	22	47	80	16	36	48	90	35	53	100
100	M27 x 2	63	85	110	30	55	44	58	20	37	145	30	27	57	105	20	50	57	110	45	76	123
125	M27 x 2	63	85	110	30	55	44	58	20	41	145	30	27	57	105	20	50	61	140	45	76	153
160	M36 x 2	80	115	135	40	75	56	81	25	55	180	40	34	72	140	25	70	80	180	63	93	193
200	M36 x 2	80	115	135	40	75	56	81	25	55	180	40	34	72	140	25	70	80	220	63	93	233

Ø	articulación hembra	peso horquilla hembra	horquilla macho
25	0,090	0,095	0,120
32	0,120	0,095	0,120
40	0,210	0,250	0,320
50	0,350	0,250	0,320
63	0,500	0,530	0,480

Ø	articulación hembra	peso horquilla hembra	horquilla macho
80	1,070	0,530	0,480
100	1,500	1,050	1
125	2,430	1,050	1
160	5,330	2,150	2,270
200	7,020	2,150	2,270

Consulte nuestra documentación en : www.asconumatics.eu

DIMENSIONES (mm), PESOS (kg)

Fijación por articulación completa normal - CNOMO 06-07-10

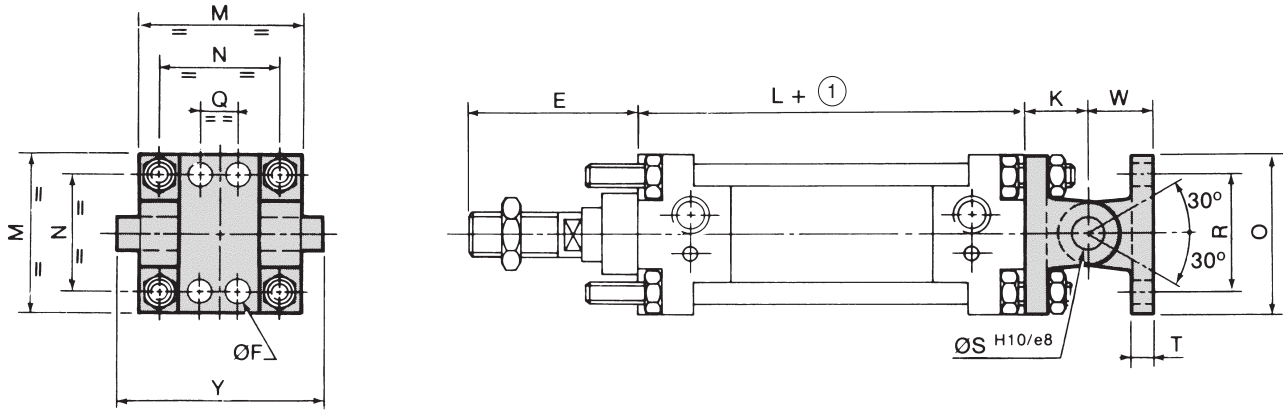

Fijación por articulación completa de escuadra - CNOMO 06-07-11

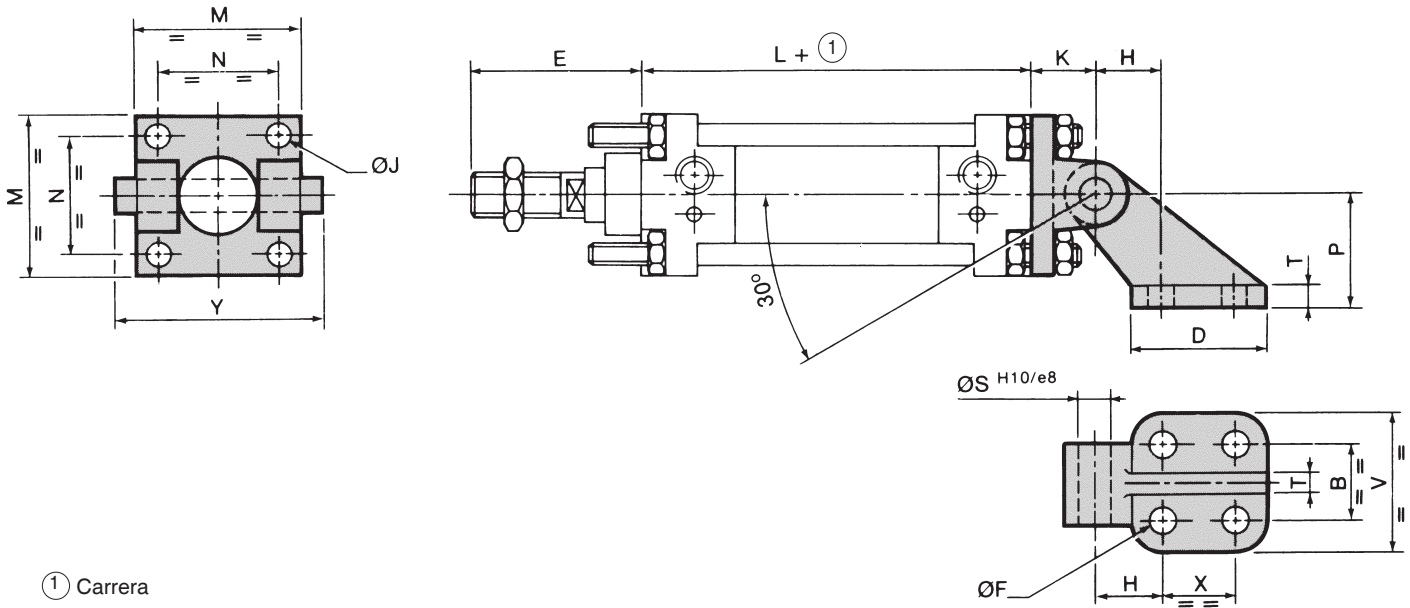

① Carrera

Ø	B	D	E	ØF	H	ØJ	K	L	M	N	O	P	Q	R	ØS	T	V	W	X	Y
25	25	37	45	7	18	7	18	80	40	28	40	32	0	28	8	8	41	18	20	49
32	25	37	45	7	18	7	18	80	45	33	40	32	0	28	8	8	41	18	20	54
40	32	54	70	9	25	7	24	110	52	40	52	45	16	38	12	10	52	26	32	62
50	32	54	70	9	25	9	26	110	65	49	52	45	16	38	12	10	52	26	32	70
63	40	75	85	11	32	9	30	125	75	59	75	63	25	54	16	12	63	34	50	80
80	40	75	85	11	32	11	32	125	75	75	75	63	25	54	16	12	63	34	50	100
100	50	103	110	14	40	11	37	145	115	90	115	90	32	90	20	16	80	41	70	123
125	50	103	110	14	40	14	41	145	115	110	115	90	32	90	20	16	80	41	70	153
160	63	154	135	18	50	18	55	180	180	140	180	140	43	150	25	20	103	55	110	193
200	63	154	135	18	50	18	55	180	180	175	180	140	43	150	25	20	103	55	110	233

Ø	peso	
	completa normal	completa de escuadra
25	0,180	0,240
32	0,210	0,280
40	0,410	0,550
50	0,540	0,720
63	1,040	1,360

Ø	peso	
	completa normal	completa de escuadra
80	1,610	1,930
100	2,280	3,270
125	3,330	4,350
160	7,480	12,020
200	9,290	12,230

00343ES-2005/R01 Las especificaciones y dimensiones pueden ser modificadas sin previo aviso. Todos los derechos reservados.

DIMENSIONES (mm), PESOS (kg)

Fijación por charnela macho - CNOMO 06-07-12

Nota : La charnela macho se suministra montada.

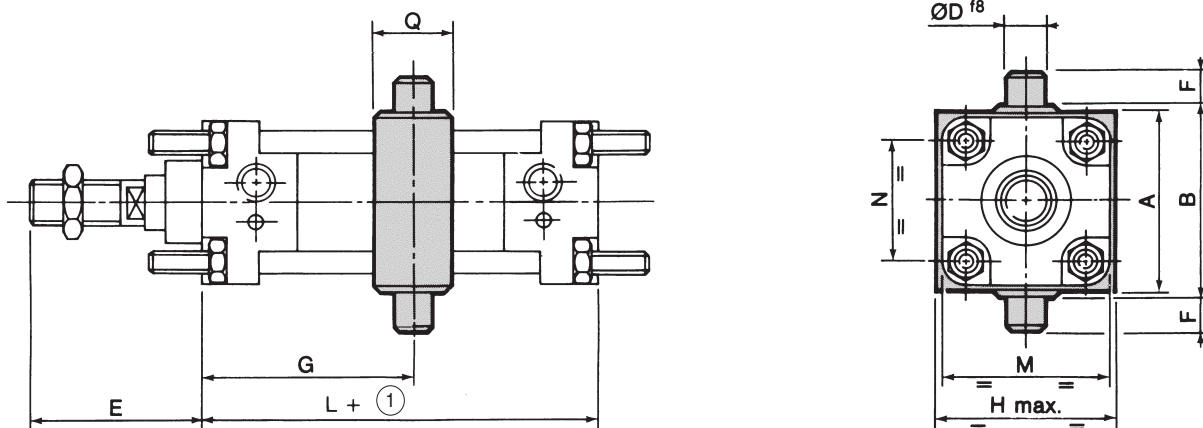

① Carrera

Ø	A	B	D	E	F	H	L	M	N	Q	sin detectores		con detectores			peso charnela sola
											Gmin.	Gmax.	Gmin.	Gmax.	Cmin.	
25	38	42	12	45	12	60	80	40	28	22	38	42 + ①	80	① - 10	90	0,140
32	46	50	12	45	12	65	80	45	33	22	45	45 + ①	97	① + 10	90	0,180
40	58	63	16	70	16	75	110	52	40	30	66	63 + ①	118	① + 20	95	0,380
50	68	73	16	70	16	90	110	65	49	30	55	63 + ①	118	① + 20	95	0,460
63	84	90	20	85	20	100	125	75	59	35	77	69 + ①	129	① + 30	100	0,820
80	102	108	20	85	20	125	125	95	75	35	77	69 + ①	129	① + 30	100	1,060
100	124	131	25	110	25	140	145	115	90	40	76	89 + ①	130	① + 10	120	1,800
125	152	159	25	110	25	170	145	140	110	40	76	89 + ①	130	① + 20	115	2,490
160	190	198	32	135	32	215	180	180	140	50	84	116 + ①	145	① + 20	130	4,170
200	240	248	32	135	32	250	180	220	175	50	84	116 + ①	145	① + 25	120	4,200

Sin indicación precisa en el pedido, todo cilindro de carrera standard se suministra con la cota G conforme al cuadro de abajo.
Para todo cilindro con carrera no standard CNOMO, la cota G debe precisarse en el pedido teniendo en cuenta los mínimos y máximos definidos en el cuadro de arriba

Cota G : según la norma CNOMO.

Ø	carrera (mm)												
	50	100	150	200	250	300	400	500	600	700	800	900	1000
25 - 32	54	75	96	117	137	-	-	-	-	-	-	-	-
40 - 50	67	87	108	129	150	171	212	-	-	-	-	-	-
63 - 80	-	94	115	135	156	177	219	260	302	-	-	-	-
100 - 125	-	102	123	144	165	185	227	269	310	352	394	434	477
160 - 200	-	-	137	158	179	200	242	283	325	366	408	450	492