

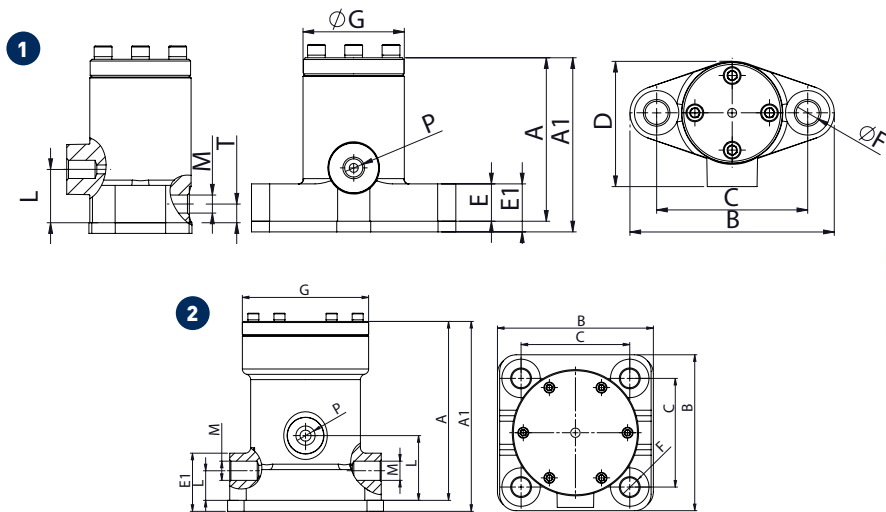

P - Linear pneumatic vibrators - Continuous impact



OVERALL DIMENSIONS																															
Type	Draw.	A		A1		B		C		D		E		E1		F		G		H		P		L		M		N		Weight	
		mm	in	mm	in	mm	in	mm	in	mm	in	mm	in	mm	in	mm	in	mm	in	mm	in	IN BSP	mm	in	OUT BSP	mm	in	kg	lb		
P25	1	92	3,62	98	3,90	115	4,52	85	3,34	70	2,75	21	0,80	27	1,06	13	0,51	58	2,28	30	1,18	1/4"	10,5	0,41	1/4"	25	0,98	2,2	4,9		
P40	1	121	4,76	127	5,00	148	5,8	110	4,33	91	3,58	25	1,00	31	1,22	17	0,67	75	2,95	45	1,77	3/8"	16	0,63	3/8"	35	1,37	4,5	9,9		
P60	2	163	6,41	173	6,4	138x142	5,4x5,5	99x99	3,9x3,9	125	4,92	28	1,1	38	1,50	17	0,67	115	4,52	60	2,36	1/2"	27	1,06	2x1/2"	60	2,36	11	24,3		

FEATURES																								
Type	2 bar - 29 psi						4 bar - 58 psi						6 bar - 87 psi											
	Vibration		Force		Dynamic Moment		Air Consump.		Vibration		Force		Dynamic Moment		Air Consump.		Vibration		Force		Dynamic Moment		Air Consump.	
	V/min	N	lb	kg*cm	in*lb	U/min	Cfm	V/min	N	lb	kg*cm	in*lb	U/min	Cfm	V/min	N	lb	kg*cm	in*lb	U/min	Cfm			
P25	2500	294	66,1	0,43	0,37	55	1,94	3800	680	152,9	0,43	0,37	80	2,83	4500	954	214,5	0,43	0,37	200	7,1			
P40	1650	484	108,8	1,63	1,41	31	1,09	2200	860	193,3	1,63	1,41	120	4,24	2800	1396	313,8	1,63	1,41	250	8,8			
P60	1200	1296	291,3	4,11	3,57	100	3,53	1600	2304	517,9	4,11	3,57	250	8,83	1900	3250	730,6	4,11	3,57	400	14,1			

P - LINEAR PNEUMATIC VIBRATORS - CONTINUOUS IMPACT

APPLICATION	Hopper silo - salt spreader - dump trailer - rail cart
POWDER	Hygroscopic - humid - sticky
PROBLEM SOLVING	Bridge and rat-holing

FEATURES

DUTY CYCLE	Continuous
WORKING PRESSURE	From 2 bar to 6 bar (from 29 psi to 87 psi)
PNEUMATIC CIRCUIT	Filter + flow control valve + lubrication + 3/2 ways valve
AIR SUPPLY QUALITY	Class 5.4.4.
WORKING TEMPERATURE	From -20°C to 200°C (from -4°F to 392°F)
MAX NOISE LEVEL	100 dB(a)
TECHNOLOGY	Piston pneumatic impact
MATERIAL	Grey cast iron body (powder painted) - aluminium cover

OPTIONS

KIT ATEX	II 2D CT(X) / II 2G CT(X)
SAFETY CHAIN	Available

